



**Best Single Source Plus (BSS+)
Emergency Solutions Grant - CARES Act (ESG-CARES [CV])
Partner Standard Operating Procedures**

BSS+ ESG-CARES [CV] COVID-19 Relief Overview

In response to the COVID-19 pandemic, the City of Austin has provided a grant to BSS+ to fund qualified social service providers with demonstrated experience providing rapid rehousing, case management and financial assistance to individuals experiencing literal homelessness. Eight members of the BSS+ Collaborative [C] will provide interventions in a safe manner in accordance with social distancing standards. Funds will provide temporary, immediate and equitably focused direct services and financial assistance to vulnerable residents.

ESG-CARES [CV] funding will target relief and services to be provided from February 1, 2021 through September 30, 2022.

Objective: To facilitate a return to permanent housing for individuals and families who are experiencing literal homelessness or who are fleeing domestic violence with no resources for housing and who are at risk of contracting COVID-19 due to their housing status.

Strategy:

Primary recruitment is through ECHO's Coordinated Entry list, with a primary focus on those living in Protective Lodges and other clients who have the greatest vulnerability.

Potential rapid rehousing (RRH) clients who contact BSS+ at Caritas or one of the other seven agencies participating in ESG-CARES [CV] will be referred to 211 for information on completing the Coordinated Assessment administered by the Ending Community Homelessness Coalition (ECHO).

At enrollment, eligible and suitable clients will define needs. Rental and utility assistance will be the default focus with stability planning in case management to discuss other needs that may be covered financially by the program.

BSS+ ESG-CARES [CV] administrative team members and Caritas Finance staff will review and process all ESG-CARES [CV] check requests. Any phone and email communication for BSS+ ESG-CARES [CV] will be separate from regular or traditional BSS+.

BSS+ ESG-CARES [CV] Program

The BSS+ ESG-CARES [CV] Program launches on February 1, 2021 and ends on September 30, 2022. ESG-CARES [CV] is a completely different and separate program from traditional BSS+. While ESG-CV is provided by the City of Austin, the funding originates from U.S. Housing and Urban Development [HUD]. Caritas of Austin is the lead and fiscal agent for the BSS+ ESG-CARES [CV] Program.

BSS+ ESG-CARES [CV] PARTNERS

Clients must meet the eligibility criteria of the individual the agency that they are applying to in addition to BSS+ ESG-CARES [CV] Screening requirements. The following BSS+ Collaborative Partners are participating in the ESG-CARES [CV] Program:

- Any Baby Can
- Caritas of Austin [lead and fiscal agent]
- Foundation for Homeless
- Front Steps
- LifeWorks
- SAFE Alliance
- The Salvation Army
- Vivent Health

BSS+ ESG-CARES [CV] COMMUNICATIONS

Information about BSS+ ESG-CARES [CV] Program and Coordinated Entry was sent to 211. Austin Public Health distributes contact information for all agencies which receive ESG-CARES [CV] funding. BSS+ Admin team and all participating partners are responsible for communication about all issues related to the BSS+ ESG-CARES [CV] Program.

BSS+ WEBSITE SUPPORT FOR ESG-CARES [CV]

There is a special BSS+ ESG-CARES [CV] Initiative menu tab on the BSS+ Website, which has all the program forms and information that Program Managers and Case Managers need. If you have any questions or there are forms you can't find, please contact: Linda Horbal at lhorbal@caritasofaustin.org or Darnise Jones at djones@caritasofaustin.org

PROGRESSIVE ENGAGEMENT WITHIN BSS+ ESG-CARES [CV] & RAPID REHOUSING

As with all BSS+ Programs, partner staff will adhere to the philosophy and practice of Progressive Engagement. Because staff will only be serving individuals found on the Coordinated Entry list, all clients will be experiencing literal homelessness and/or will be fleeing or attempting to flee domestic violence. ECHO staff will work closely with partner BSS+ Program Managers on referrals, and are making it clear to clients that, when participating in the BSS+ ESG-CARES [CV] Program, that they are participating in Rapid Rehousing Program.

The amount of time individuals and households have had to survive in homeless conditions, and the physical and mental health conditions of the individuals themselves, will impact the types of services clients may need immediately. The results of each Coordinated Assessment will provide case managers with a foundation of knowledge about the needs of all individuals and/or households referred, which should be of benefit.

Progressive Engagement services start with the least intensive service and amount of subsidy—i.e., “light touch”—and progress to greater service intensity only when necessary. The need for additional support is determined by an assessment of an individual’s or household’s experience, self-reporting, and the impact of the initial intervention. Client choice, to the extent possible, drives the housing options and services offered.

By using a Progressive Engagement approach, assistance can be tailored to meet the most critical needs of individuals and/or households first, with a keen focus on quickly resolving the housing crisis.

ELIGIBILITY AND INTAKE

To ensure compliance with eligibility criteria outlined by the City of Austin as well as other BSS+ ESG-CARES [CV] criteria, staff will collect standardized information to verify eligibility of all clients referred from the Coordinated Entry list.

1. Eligible clients must
 - a. Meet the HUD definition for *Category 1 – Literally Homeless* or *Category 4 – Fleeing or Attempting to Flee Domestic Violence* and must be referred from the Coordinated Entry list.

HUD Homeless Definition

Category 1: Literally Homeless – An individual or family who lacks a fixed, regular and adequate nighttime residence, meaning

- I. Has a primary nighttime residence that is a public or private place not meant for human habitation;
- II. Is living in a publicly or privately-operated shelter designated to provide temporary living arrangements? This includes:
 - o Congregate shelters
 - o Transitional housing
 - o Hotels and motels paid for by charitable organizations or by federal, state, and local government programs; *or*
- III. Is exiting an institution where they have resided for 90 days or less and who resided in an emergency shelter, or a place not meant for human habitation immediately before entering that institution.

Category 4: Fleeing/Attempting to Flee Domestic Violence

- I. Is fleeing or attempting to flee their housing or place they are staying because of domestic violence, dating violence, sexual assault, stalking, or other dangerous or life-threatening conditions related to violence that has taken place in the house or has made them afraid to return to the housing, including:
 - o Trading sex for housing
 - o Trafficking
 - o Physical abuse
 - o Violence (or perceived threat of violence) because of youth’s sexual orientation
 - II. Has no other residence; and
 - III. Lacks the resources or support networks to obtain other permanent housing.
-

OR

- b. Meet all of the following requirements (for clients involved in a program transfer):
 - be enrolled in a time-limited rental assistance program, other than ESG-CV, which is expiring (i.e., no more rental assistance is available to the client; the length of available case management is not a factor)
 - have been experiencing homelessness just before enrollment in the expiring rental assistance program
 - have been referred into the expiring rental assistance program through the Coordinated Entry process
 - have no overlap of assistance between the expiring rental assistance program and BSS+ESG-CV
 - have a gap of no more than one month between exit from the expiring rental assistance program and enrollment into BSS+ ESG-CV
 - lack the resources to maintain their housing without the assistance of the BSS+ ESG-CV program
 - coordinate programmatic transfer with Caritas' BSS+/ESG-CV Program Manager, who will facilitate the necessary Coordinated Entry transfer with ECHO

2. Program clients served must provide documentation for eligibility requirements at entry. Eligibility documentation requirements are listed on the client's file checklist form. However, there is special information for program transfers, which may be found by following the pathway listed below:

BSS+ Website<Menu<BSS+ ESG-CARES (CV) Initiative<BSS+ ESG-CARES (CV) Program Forms<BSS+ ESG-CV Program Transfer Waiver Workflow

3. At the beginning of the intake process, case managers should review a potential client's service transactions in HMIS to make sure the individual has not already exhausted BSS+ ESG-CV financial support working with another partner agency.

Typical Questions Related to Client Eligibility

- **Can a client who is enrolled in the BSS+ ESG-CARES [CV] Program also participate in the regular BSS+ Program?**
 - *Yes, only in a special BSS+ Supportive Services Only category. This new service is called BSS+ SSO. Clients enrolled in BSS+ ESG-CARES [CV] can use the BSS+ SSO, which involves funds that come out of a partner's regular BSS+ budget, if needs require. There is no program enrollment for BSS+ SSO; it is a service within BSS+ ESG-CV. Although, when you enter data into HMIS, it is considered a "program entry," and before using SSO funds, the case manager needs to enroll the client in SSO in the Program Entry/Exits area in HMIS. [There is a special SSO EDA in HMIS.]*

- *No separate enrollment forms are necessary for clients utilizing BSS+ SSO, since it is a service of ESG-CV. However, a separate tab should be kept within the ESG-CARES [CV] client file for tracking BSS+ SSO expenses. The BSS+ SSO Expense Tracking form is used to record BSS+ SSO expenses.*
- *Keep in mind that there are separate tracking forms for ESG-CARES [CV] expenses: see rental assistance tracking form and utility assistance tracking form.*

BSS+ SSO expenses are funded from the pot of available direct client assistance under the regular BSS+ grant. No additional funds have been secured for this service. Therefore, BSS+ SSO funds should only be used when no other financial assistance can be secured for the expense not covered under ESG-CARES [CV]. Hotel expenses, household items and ID assistance are examples of expenses that the Case Manager might consider for utilization of funds under BSS+ SSO. SSO funds are not for rental and utility assistance, since they are expenses that can be paid by ESG-CV funds.

- **Do I have to complete regular BSS+ paperwork, if I am only enrolling a client in the BSS+ ESG-CARES [CV] Program?** *No, only complete BSS+ ESG-CARES [CV] paperwork. If you have questions, please contact the BSS+ Admin staff.*
- **Can former clients who exited the regular BSS+ Program less than 1 year ago be enrolled in BSS+ ESG-CARES [CV]?** *Yes, in ESG-CARES [CV] and, also, the client can use the ESG SSO.*
- **If clients exit BSS+ ESG-CARES [CV], and afterwards become homeless again and re-appear on the Coordinated Entry list, can these individuals be served by another partner participating in BSS+ ESG-CV?** *It depends! If a client exits before receiving all 12 months of rental assistance, utility assistance or another allowable expense—and still has financial support left—the second partner can re-enroll the client and provide the balance of the benefits. Under no circumstance, can a client who has received the maximum allowable BSS+ ESG-CV financial support be re-enrolled with another partner agency to receive additional funding support. To serve a client who has already participated with another BSS+ ESG-CARES (CV) partner agency, please contact Linda Horbal at lhorbal@caritasofaustin.org, so she can help make the transition a smooth one.*
- **Is a regular, currently enrolled BSS+ Client eligible to be enrolled in BSS+ ESG-CARES [CV]?** *No. Referrals to the BSS+ ESG-CARES [CV] program must be made through Coordinated Entry specifically for BSS+ ESG-CV.*
- **Are individuals experiencing homelessness and/or domestic violence exempt from income requirements in BSS+ ESG-CARES [CV] at entry to the program?** *Yes; although, when recertifying the client after one year in the program, income is considered. The requirement is for the client to be 30% of Area Median Income or less.*

Intake Process

- **Reminder:** all clients must be taken from the Coordinated Entry list. The partner agency's BSS+ Program Manager will work with Allison Mabbs at ECHO to secure a list of ESG-CARES [CV] clients for which your agency has capacity. *Tip: if you have capacity for 5 clients, you probably should ask for 10 from ECHO, since it takes time to track down clients from Coordinated Entry list.*
- Start with the BSS+ ESG-CARES [CV] Rapid Rehousing [RRH] Screening form, unless the client is a program transfer, to determine if the client is eligible and complete intake (see BSS+ ESG-CARES [CV] Workflow).
- Unless the client is a program transfer, all adults in a household must complete the "Self-Declaration of Homelessness, Identity, and Income Exemption" form in the "Homelessness" section to confirm literal homelessness and/or fleeing domestic violence. Do not forget to complete the "Required Information" section on the form. [Included on the ESG RRH Client File Review Form]
- Collect all required documentation (see File Checklist) to attach to the screening form.
- Enter intake information into HMIS under the special BSS+ ESG-CV EDA. Remember, this is a separate enrollment in the client's HMIS account. You only enter the client in the BSS+ SSO EDA in the Program Entry/Exits area in HMIS when he/she is participating in the SSO after being enrolled in BSS+ ESG-CARES [CV]. The client does not need to be entered with the SSO EDA until/unless SSO funds are utilized.
- ***If a case manager does not have the BSS+ ESG-CARES [CV] EDA or BSS+ SSO EDA, please contact the ECHO IT Help Desk at austinecho.org, so they can assign it. BSS+ Admin staff do not have permission to make these assignments.***

FINANCE WORK PROCESSES

Submitting ESG-CARES [CV] Check Requests and Reimbursement Requests:

- Special ESG-CARES [CV] check request forms have been printed.
- **Send all BSS+ ESG-CARES [CV] Check Requests to the BSS+ ESG-CV Mailbox: bssesg-cv@caritasofaustin.org (Please do not send BSS Plus check requests to the regular BSS+ Mailbox or bssplus@caritasofaustin.org)**
- Fax BSS+ ESG-CV Check Requests to 512-735-2053

- No Extension Requests are needed for ESG-CV, since there are no client financial caps.
- Label any emails, whether questions, check or reimbursement requests concerning ESG-CARES [CV], by placing “ESG-CARES [CV]” in email subject line, with the client’s SPID or ID number and check request/voucher number. For example: **LW_SPID#123456_CR 97454_ESG-CV** [LW stands for LifeWorks; please put an agency identifier at the beginning of your document label]
- BSS+ ESG-CARES [CV] check requests are vetted by BSS+ Admin staff before being sent to Finance for processing. If we need further clarification and/or documentation, we will respond ASAP.
- BSS+ ESG-CARES [CV] check requests are posted in a separate ESG-CARES [CV] Check Request Log located in the ESG-CARES [CV] tab on the BSS+ website.
- All BSS+ ESG-CARES [CV] check requests are subject to the same documentation requirements as regular BSS+ requests, including entering of service transactions, LLVs, ledgers if needed, leases, eviction letters, etc. If you have questions about whether a document should be included, please refer to these *BSS+ ESG-CARES [CV] Partner Standard Operating Procedures* before sending a check request to BSS+ ESG-CARES [CV] Mailbox. If you are confused or still have questions, please email staff for clarification: Linda Horbal at lhorbal@caritasofaustin.org or Darnise Jones at djones@caritasofaustin.org
- BSS+ ESG-CV Check Requests for rental assistance should not be requested before the ESG-CV Landlord Rental Assistance Agreement for a particular unit is signed and dated. *Producing checks to a landlord/property manager for expenses like rental assistance dated before the agreement is signed is considered a “finding” by HUD.*
- A copy of the fully executed **ESG-CV Rental Assistance Agreement** must be included with the check request for the first month’s rent.
- A copy of the **ESG-CV Landlord Incentive Agreement Addendum** must be included with any check request submitted for an expense that is classified as a signing bonus. See the section on “Landlord Incentives” in this document. for a detailed list of expenses classified as a signing bonus.

Submitting BSS+ SSO Check Requests and Reimbursement Requests:

- Use the traditional BSS+ Check Request form. Write SSO in bold letters at the top.

- **Send all BSS+ SSO Check Requests to the BSS+ ESG-CV Mailbox: bssesg-cv@caritasofaustin.org (Please do not send SSO check requests to the regular BSS+ Mailbox or bssplus@caritasofaustin.org)**
- Fax ESG SSO Check Requests to 512-735-2053
- No Extension Requests are needed for BSS+ SSO.
- Label any emails, whether questions, check or reimbursement requests concerning BSS+ SSO, by placing “BSS+ SSO” in the email subject line, with the client’s SPID or ID number and check request/voucher number. For example: **LW_SPID#123456_CR 97454_BSS+ SSO** [Please put your agency’s initials like LifeWorks LW at the beginning of the document label.]
- BSS+ SSO check requests are vetted by BSS+ Admin staff before being sent to Finance for processing. If we need further clarification and/or documentation, we will respond ASAP.
- BSS+ SSO check requests will be posted in a separate BSS+ SG SSO Check Request Log located in the ESG-CARES [CV] tab on the BSS+ website.
- All BSS+ SSO check requests are subject to the same documentation requirements as regular BSS+ and BSS+ ESG-CARES [CV] check requests. If you are confused or have questions, please email staff for clarification: Linda Horbal at lhorbal@caritasofaustin.org or Darnise Jones at djones@caritasofaustin.org
- When case managers enter BSS+ SSO service transaction data into HMIS begin by posting a program entry in the Program Entry/Exits area in HMIS with the special BSS+ SSO EDA.

Distribution of BSS+ ESG-CARES [CV] and BSS+ SSO Client Checks

- Finance staff will mail client checks to the appropriate vendor.
- As conditions allow, BSS+ Admin staff will notify Program and Case Managers when checks can be picked up at the downtown Caritas office: 611 Neches.

CLIENT FILE MAINTENANCE

- Set up a separate client file folder for the BSS+ ESG-CARES [CV] Program, following the order of the ESG-CARES [CV] file checklist.
- No separate enrollment forms are necessary for clients utilizing BSS+ ESG SSO.

- A separate tab should be kept within the ESG-CARES [CV] client file for tracking BSS+ SSO expenses. A BSS+ SSO Expense Tracking form is available to record BSS+ SSO expenses.

CLIENT CONFIDENTIALITY

All data collected through the Coordinated Entry Process is fully covered by the Continuum of Care (CoC) Privacy Protections, as laid out in the Homeless Management Information System [HMIS] Policies and Procedures. Also, client data cannot be entered into HMIS or Apricot until all adults in the household have signed their own Release of Information [ROI]. The confidentiality of all household members, including minors, is protected by the ROI.

CLIENT DATA AND DOCUMENTATION REQUIREMENTS

Staff must maintain a **record** of client eligibility and services provided:

- Case managers will establish a separate client file folder for **all** BSS+ ESG-CARES [CV] information/documentation, including expenses entered into the BSS+ SSO EDA.
- **Pre-monitoring.** BSS+ ESG-CARES [CV] client files and all documentation will be pre-monitored by BSS+ Admin staff at least twice a year at a time TBD and by Austin Public Health during their auditing process. HUD may also monitor files as a part of their audit of Austin Public Health.
- **BSS+ ESG-CARES [CV] RRH Eligibility & Screening Form** includes a checklist designating acceptable documentation of eligibility and is linked to the BSS+ Website under the menu tab “BSS Plus ESG-CARES [CV] Initiative.”
- **Proof of Homelessness** is required for eligibility at intake.
- **Proof of Residency and Income** are not required for eligibility at intake. However, if income information is available, it must be gathered and placed in the file for the purpose of budget and case management planning.
- **Proof of Identity** must be collected for each adult household member. If proof of identity is unavailable, a Self-Declaration Form may be used. If birth certificates and social security cards are available for minor children, those may also be included in the file.
- **A Self-Declaration Form may be used for the following purposes:**
 - Certification of identity if no other proof is available
 - Proof of homelessness and/or fleeing domestic violence
 - Proof of no, partial or undocumented income

HOUSEHOLD ASSISTANCE

Case managers will explore with eligible clients to determine their needs, including completing a Housing Stability Case Plan and budget to also see what other community relief is available.

1. BSS+ ESG-CV Allowable Expenses:

- **Rental Assistance:** Maximum of 12 months rental assistance (no late fees or pet fees). If late fees occur while program is paying rent, they must be covered by non-ESG funds. *The initial term of the lease cannot be less than one year.*

Rental assistance can be paid to Community First Village, if the client's housing is considered permanent and it passes the *ESG-CARES [CV] Minimum Habitability Standards*.

- **Pro-rated Rental Assistance:** Pro-rated or partial payment of rent is counted as one month's assistance. Although, the balance from that rent is still available to the client, as long as they are still enrolled in ESG-CV.
- **Tenant-based Rental Assistance.** Rental assistance for this program will be tenant-based, and all program support will provide the minimum amount of assistance needed for client to stabilize using the principles of Progressive Engagement. *[Exhibit D. 1 – ESG Program, Standards, and Policies, page 13 of 21]*
 - A client who receives tenant-based rental assistance may select a housing unit in which to live and may move to another unit or building and continue to receive rental assistance, as long as the program participant continues to meet program requirements.
 - BSS+ ESG-CARES [CV] requires that all program participants live within Austin/Travis County for the period in which rental assistance is provided.
 - BSS+ ESG-CV clients can live in group housing, and may have a roommate, if the client has a separate lease and rental amount established with the property. *(24 CFR 576.106)*
 - The ESG-CARES [CV] rental assistance agreement with the owner/landlord must terminate and no further rental assistance payments under that agreement may be made if:
 - The client who is a program participant moves out of the housing unit for which the program participant has a lease;
 - The client becomes ineligible to receive BSS+ ESG-CARES [CV] rental assistance; or
 - The lease terminates and is not renewed.

- **Last Month's Rent.** If necessary to obtain housing for a client, the last month's rent may be paid from BSS+ ESG-CARES [CV] funds to the owner/landlord of that housing at the time the owner/landlord is paid the security deposit and the first month's rent. Feedback we have received is that asking for the last month's rent is infrequent. This assistance must not exceed one month's rent and must be included in calculating the program participant's total rental assistance.

Please Note: *If you add last month's rent required by a landlord/property manager to a check request form in the Rental Assistance box, be sure and explain this expense on the "Additional Information" line of the form.*

- **Rental Arrears/Debt:** can pay up to 6 months of rental debt, which does not count toward the 12 months of rental assistance. If the client owes more than 6 months of arrears, consider paying the overage from regular BSS+ Program via BSS+ SSO EDA. BSS+ ESG-CARES [CV] will not pay more than 6 months of arears under any circumstance. *Payments may only be made to a landlord and may not be made to a collection agency.*
- **Application and Administrative Fees:** can pay related application and administrative fees that the landlord charges in the course of qualifying any client for rental eligibility.
- **Security Deposit:** Cannot exceed 3 months' rent; can be paid before the Landlord Rental Assistance Agreement is signed and/or Habitability Inspection is completed.
- **Landlord Incentives:** Landlord incentives include:
 - signing bonuses which include
 - Any monies paid to incentivize the landlord to expand tenant screening criteria
 - Any type of deposit that is not refundable to the tenant or that cannot be used toward tenant's remaining balance owed at the end of the lease
 - Second chance deposits
 - Risk fees
 - Risk mitigation fees
 - Any fee or charge with the words risk, risk mitigation, incentive or bonus in the description
 - repairs and/or cleaning of the rental unit while the client is occupying the unit

Total landlord incentives (signing bonus, repairs, cleaning) plus payment of security deposit cannot exceed a cumulative total of more than 3 months' rent.

- **Utility Assistance:** Maximum of 12 months of utility assistance (electric, natural gas, propane, fuel oil, wood or coal) **per utility** is allowable and does not count toward rental assistance; functions or "end uses" covered by an allowance may include space heating, water heating, cooling refrigeration, lighting, appliances, water, sewage services, as well as garbage collection

A partial payment of a utility bill counts as one month. This assistance may only be provided if the program participant or a member of the same household has an account in his or her name with a utility company or proof of responsibility to make utility payments. [Exhibit D. 1 – ESG Program, Standards, and Policies, page 17 of 21]

- **Utility Debt:** Up to 6 months utility debt can be paid **per utility**. However, utility debt payments combined with regular utility payments cannot exceed 12 months. So, if BSS+ ESG pays 3 months of utility debt (arrears), in order for client to have electricity turned on in their name, BSS+ ESG-CARES [CV] can only pay another 9 months of electric payments. (Utility deposit does not count against 12 months of utility assistance.)
- **Moveout Fees:** can pay client move out fees to include remaining balance of rent, utilities, pest control and repairs, if needed
- **Moving expenses:** can pay and do not deduct from other available assistance
- **Storage Fees:** Up to 3 months and insurance (protection plan), if required by contract
- **Renter’s Insurance:** allowable, if required by the lease:
 - If renter’s insurance is included with rental expense each month, then it is posted on the Check Request form and in HMIS in the “Rental Assistance” section.
 - If renter’s insurance is paid separately by client, it is posted in the “Utility Assistance” section on the Check Request form and in HMIS. Also, the case manager works with client to take over future payments as they become more self-sufficient.
 - Traditional renter’s insurance benefits a client in the event of a client’s property loss.
- **Property Liability Insurance/Fees:** The grant will pay these fees—and fees characterized as ‘renter’s insurance’ even if the benefits are paid to the property—if the lease contract requires the payments be made by the tenant.
- **Legal expenses:** that are primarily related to clients obtaining and/or maintaining housing, which includes landlord/tenant and eviction issues, to the extent that appropriate legal services are unavailable or inaccessible within the community. Eligible subject matters are:
 - Child support
 - Guardianship
 - Paternity
 - Emancipation, and legal separation
 - Orders of protection and other civil remedies for victims of domestic violence, dating violence, sexual assault and stalking
 - Appeals of veterans and public benefit denials

- Resolution of outstanding criminal warrants

Not Allowable Expenses for ESG-CARES [CV], but may be considered under BSS+ ESG SSO:

- Hotels/motels
- Board and care facilities
- Identification (birth certificates, driver's license)
- Food
- Furniture
- Internet, telephone service and/or mobile telephones/minutes
- Transportation (bus passes, cabs)
- Legal expenses for immigration and citizenship matters, and issues related to mortgages, are ineligible costs; retainers and contingency fee arrangements are ineligible costs
- Rental debt paid to a collection agency
- Except for a one-time payment of rental arrears on the tenant's portion of a rental payment, ESG-CARES [CV] rental assistance cannot be provided to a program participant who is receiving tenant-based rental assistance or living in a housing unit receiving project-based rental assistance or operating assistance, through other public sources. [Exhibit D. 1 – ESG Program Standards, and Policies, page 12 of 21]

Special Note:

- ESG rental assistance cannot be used in a public housing unit
- ESG rental assistance cannot be provided to someone with a Section 8 voucher
- ESG rental assistance cannot be used in a unit with project-based Section 8 funding
- ESG cannot be used for a Continuum of Care (CoC) funded unit: (i.e., some Green Doors units are CoC funded.)

There is a difference between a tax credit property and public housing. Tax credit properties commit a certain number of affordable units for a tax break. These are private entities. ESG funds can be used at tax credit properties, but not public housing.

Please be aware that a client cannot receive funding from both BSS+ SSO and BSS+ ESG-CARES [CV] for the same expense in the same month. For example, if BSS+ ESG-CARES [CV] funds pay for May rental assistance then BSS+ SSO funds cannot be used for rental assistance for the same month.

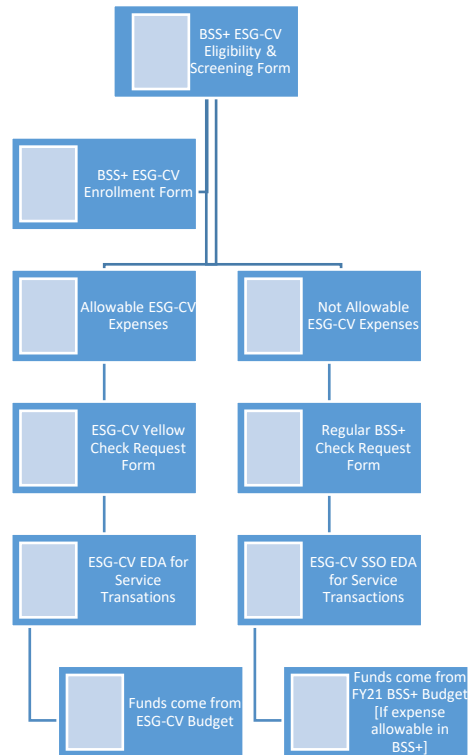

HOUSING LOCATION SERVICES AND SUPPORT **Timelines are reflected in blue*

Caritas of Austin’s BSS+ Community Housing Specialists (CHS) will offer individualized housing location services and support for clients served by the BSS+ ESG-CARES [CV] Program. A case manager who wishes to utilize these services can make a referral by completing the following steps:

1. Case manager completes a CHS intake/referral form and compiles documentation as detailed on the BSS+ ESG-CV CHS Referral Checklist and emails the referral packet to the BSS+ Referral Mailbox at esgreferrals@caritasofaustin.org or via fax at 512-735-2007
2. Within one business day of referral form receipt, BSS+ staff member distributes referral to individual CHS and manages caseloads between the two CHS assigned to BSS+-ESG.
3. CHS reviews referral and supporting documents and makes email and/or telephone contact with Case Manager within two business days of receipt of referral from the BSS Program Director. This contact will confirm assignment of referral and clarify any information to begin housing search. CHS will then begin the process. Based on this timeline, the housing search process begins no later than the third business day after the referral is received by the BSS+ ESG Referral Mailbox esgreferrals@caritasofaustin.org

4. CHS will communicate status of housing search no later than the seventh business day after the initial referral was made to the BSS+ ESG Referral Mailbox and at intervals no longer than every 5 business days thereafter.
5. CHS will provide a maximum of 3 units within the boundaries of the client preference sheet. If client refuses all 3 units, the responsibility for identifying units will be turned back over to the client and case manager.
6. The CHS is available to assist with negotiation of fees and deposits, to facilitate and advise in the application process, to schedule the viewing of rental units, and to assist with completion of all forms up to the point of final execution and signing. This may include consultation with the case manager, client and property management staff either in person, via video conference or teleconference. **However, the Case Manager must participate in any meeting in which the client is a participant.**

The Community Housing Specialist will not, at any time, engage with the client without the participation of the Case Manager. This includes any type of communication to include email and telephonic communication. *The CHS' phone number and email address should not be given directly to the client.*

7. Case Managers are encouraged to utilize the CHS for completion of the Rent Reasonableness Form, but the Case Manager is ultimately responsible for ensuring the form is included in the client file.
8. Case manager is responsible for working with the client to complete visits to view possible rental units, as well as the final signing and execution of all documents to include applications, the rental assistance agreement, and the lease signing.
9. The habitability inspection is completed by the case manager. The client does not have to be present for the completion of the inspection, although, it is recommended that the client be present.
10. Case manager will retain all community housing documentation related to the housing process (case notes, emails concerning housing discussions, etc.) in the client's file for purposes of BSS+ pre-monitoring in addition to City or HUD audits.
11. The overall goal for "days to housing" is 90 days from client's entry into the BSS+ ESG-CARES [CV] Program.

12. After the client is housed, the Case Manager is encouraged to maintain a relationship with the property management to ensure that any concerns or issues on either the part of the client or the property management can be rectified productively and quickly. The CHS Staff are available, at the request of the case manager, to assist with specific concerns as they arise.

****BSS+ ESG-CV Habitability Inspection, Rent Reasonableness Form and Rental Assistance Agreement must be complete before submitting a check request for first month's rent.***

****BSS+ ESG-CV Landlord Incentive Agreement Addendum must be complete before a check request is submitted for payment of a signing bonus.***

POLICIES AND PROCEDURES FOR RENT REASONABLENESS

While this BSS+ ESG-CARES [CV] grant has a waiver that does not require rent to be at or below Fair Market Rent (FMR), it is not advisable to move a client into a rental unit that exceeds FMR, as client ability to maintain rental payments after exit from the program must be considered. A Rent Reasonableness Analysis must be completed for rental units which are paid for using BSS+ ESG-CARES [CV] funds.

- To be considered reasonable, rent:
 - Must be realistic and sensible in comparison to rents currently charged for similar units in the private unassisted market in the area; and
 - Must not be exceed defined limits of rent amounts charged for similar unassisted units; and
 - For multi-family apartment communities, must be comparable to similar units on the premises.
- Utilizing the Rent Reasonableness Form, Gross Rent information must be collected for at least 3 comparable unassisted rental units within the area. *Units used for comparison should be no more than 100 sq. feet larger or smaller than the proposed unit.*
- Rent for a proposed unit may be considered “reasonable” if its Gross Rent is no more than 5% above the average Gross Rent of the comparable units analyzed. Please refer to Rent Reasonableness Form for further instruction.
- Please refer to Guidelines for Calculating Rent Reasonableness, located on the BSS+ Website: Menu < BSS+ ESG-CARES [CV] Initiative < BSS+ ESG-CARES [CV] <Community Housing Information <Guidelines for Calculating Rent Reasonableness

PROCEDURES FOR NEGOTIATION OF LEASE TERMS

Case Managers may assist the client in standard negotiation of lease terms, or they may elect to utilize the assistance of the BSS+ ESG-CARES [CV] Community Housing Specialist Team. The following are the maximum allowable security deposits/signing bonuses:

If not utilizing a signing bonus:

A security deposit of up to three months' rent.

If utilizing a signing bonus:

- As security deposit of up to two months' rent
- A signing bonus equaling the lesser of \$1000 or one-months' rent

Both Case Managers and Community Housing Specialists will adhere to the following guidelines when negotiating lease terms:

- Negotiations will begin at the lowest level deemed possibly effective and work up to the maximum recommended level
- Traditional deposit strategies will be prioritized above signing bonuses, as the deposit is more beneficial to the client in the long-term
- *Any proposed terms outside of the above negotiation structure must be pre-approved by the Director of BSS+ Programs.*
- *All negotiated terms must be reflected in the BSS+ ESG-CARES [CV] Rental Assistance Agreement and BSS+ ESG-CARES [CV] Landlord Incentive Agreement Addendum (when indicated).*

POLICIES AND PROCEDURES FOR COMPLETING BSS+ ESG-CARES [CV] RENTAL ASSISTANCE AGREEMENT WITH PROPERTY MANAGER

Landlords with whom BSS+ ESG-CARES [CV] staff are working must review and sign the BSS+ ESG-CARES [CV] Landlord Rental Assistance Agreement for each client before case managers can secure housing in a complex. Primary responsibility for working with landlords on this task is the BSS+ Community Housing Specialist in partnership with a client's case manager.

No BSS+ ESG-CARES [CV] funds can be used to pay rental assistance for a client until the Landlord Rental Assistance Agreement is signed for that particular client. Application fees and/or security deposits can be paid without the execution of the rental assistance agreement.

No BSS+ ESG-CARES [CV] funds can be used to pay an expense that qualifies as a signing bonus (see the section on “Landlord Incentives” in this document for a list of qualifying expenses) for a client until the BSS+ ESG-CARES [CV] Landlord Incentive Agreement Addendum is signed for that client. Application fees and/or security deposits may be paid without the execution of the rental assistance agreement.

POLICIES AND PROCEDURES FOR HABITABILITY INSPECTIONS

BSS+ ESG-CARES [CV] funds cannot be used to help a program participant remain in or move into housing that does not meet the minimum habitability standards under *The Emergency Solutions Grants (ESG) Program* interim rule, at 24 CFR 576.403. Note: The same standards apply regardless of the amount of ESG funds involved. For example, the recipient or subrecipient must inspect the unit and confirm that it meets the ESG minimum habitability standards, even if the only ESG assistance provided is for a security deposit or moving assistance.

When ESG Rental Assistance and/or Housing Relocation and Stabilization Services are provided to help a client move into a new permanent housing unit, the habitability standards apply to the unit into which they are moving and must be documented in the client’s file. If Rapid Re-housing services are provided before a unit has been identified, no habitability inspection is required until there is a unit to inspect. If assistance with arrears for a prior unit is needed as part of the rapid rehousing assistance, no habitability inspection is required for the old unit.

The unit into which the program participant is moving must be inspected before the client signs the lease and before the recipient/subrecipient provides any ESG rental assistance is paid. (Application fees are an exception to this requirement. If a client applies for several units, only the unit into which they ultimately decide to move must be inspected.)

If a unit fails inspection, but subsequently passes a follow-up inspection, both the initial and follow up report must be retained in the client file.

A Case Manager or Community Housing Specialist may complete inspections.

Please review the step-by-step chart at the end of the BSS+ ESG-CV Standard Operating Procedures entitled “Working with Landlords/Property Managers.”

POLICIES AND PROCEDURES TO TRACK BSS+ ESG-CARES [CV] DIRECT CLIENT ASSISTANCE

Direct client assistance will be monitored to ensure the appropriate expenditure of all funds to vendors (such as landlords) for identified needs. Please refer to the following forms for tracking Direct Client Assistance:

- Rental Assistance Tracking Template
- Utility Assistance Tracking Template

BSS+ ESG-CARES [CV] expenses are to be entered into the BSS+ ESG-CV EDA in HMIS.

POLICIES AND PROCEDURES TO TRACK BSS+ SSO DIRECT CLIENT ASSISTANCE

Direct client assistance will be monitored to ensure the appropriate expenditure of all funds to vendors for identified needs. Please refer to the following form for tracking Direct Client Assistance:

- BSS+ SSO Expense Tracking Form

BSS+ SSO expenses are to be entered into the BSS+ SSO EDA in HMIS and to do that, the case manager will need to create a “program entry” in HMIS in the Program Entry/Exits area to enroll the client in SSO in the same way you enroll a client in ESG-CV.

DATA MANAGEMENT

Each of the BSS+C partners participating in BSS+ ESG-CARES [CV] will enter client data into HMIS through ServicePoint [SP], except for SAFE Alliance which uses the web-based software Apricot. Client eligibility documents and services are collected and stored in paper files. The Release of Information will be uploaded to HMIS, as with regular BSS+ clients.

Program entry dates are entered into HMIS after all required documentation is collected and verified. No household data can be entered into HMIS until all adults in the household have signed their Release of Information form. Program expectations are communicated to the household through a signed program agreement at time of intake.

As the lead fiscal agent for BSS+C, Caritas is responsible for all program reporting, and training partners on data collection/entry. Caritas consolidates data quarterly and submits to funder. Monthly data quality checks are performed with the 8 participating BSS+C partner agencies to ensure compliance with data entry guidelines just as we do for the regular BSS+ Program.

Monthly summary reports are sent to all BSS+C agencies to confirm all client data and services. ***All BSS+C client data must be entered in HMIS within 5 days of intake or, at the latest, by the last day of the month, with data corrections completed by the 7th calendar day of a given month.***

Problems with HMIS: If you have problems with HMIS, including assignment and/or use of the BSS+ ESG-CV EDA or BSS+ SSO EDA, please contact the ECHO IT Help Desk at www.austinecho.org

BSS+ ESG-CARES [CV] RECERTIFICATION

Client eligibility re-certification is required after 1 year of participation in BSS+ ESG-CARES [CV] Program: Case Manager uses *Chance of Circumstance* form to re-certify clients at one-year anniversary. As with regular BSS+, closely follow the instructions for client recertification on the Change of Circumstance form.

- Client’s one year begins at the “program entry date.”
- 30 days prior to a client’s first anniversary in ESG-CARES [CV], a case manager will begin the recertification process to include gathering documentation.
- Clients may participate in up to 12 - 24 months of case management, but duration of case management cannot extend beyond the end of the ESG-CARES [CV] contract (9/30/2022).
- Case managers must consider client’s monthly gross income by using the Area Median Income [AMI] Chart seen below and provided on the BSS+ ESG-CARES [CV] website menu tab. Use gross amounts when calculating income. For example, if a client earns gross income of \$3,000 a month, the client’s annual income is \$36,000. If a client has a household of 3, the household is under 50% of AMI or “very low” with an annual income of \$36,000.

To remain in the program, client household income must be 50% AMI or less at recertification. If client income exceeds 50% AMI, the client must be exited from the program. If eligible, the client may be served by traditional BSS+.

Area Median Family Income [AMI] Chart

Use for BSS+ ESG-CARES [CV] One Year Client Recertification Process

**Use Gross Amounts to Calculate Annual Income*

Fiscal Year (FY) 2021 Area Median Family Income = \$98,900*			
ADJUSTED INCOME LIMITS BY HOUSEHOLD SIZE - AUSTIN/ROUND ROCK SMSA			
Household Size	Very Low	Low	Moderate
	(30% Limits)	(50% Limits)	(80% Limits)
1 person	\$20,800	\$34,650	
2 people	\$23,750	\$39,600	
3 people	\$26,700	\$44,550	
4 people	\$29,650	\$49,450	
5 people	\$32,050	\$53,450	
6 people	\$34,400	\$57,400	
7 people	\$36,800	\$61,350	
8 people	\$39,150	\$65,300	

- Email Greg Tausch at gtausch@caritasofaustin.org as you recertify clients and provide the clients' names and dates of birth, so he can track them on a separate list. Unfortunately, there is no function in HMIS that allows us to track a client who has been recertified after one year. As a result, when Greg runs data quality reports, a partner agency may receive a DQ error, until/unless you notify him that the client has been recertified.
- File all recertification forms and documentation in the client's file, since having this paperwork is subject to auditing.

EXITING CLIENTS

- BSS+ ESG-CARES [CV] clients will have the same Exit process with respect to documentation as well as HMIS data entry as does regular BSS+ clients. The same Exit form is being used for BSS+ ESG-CARES [CV] clients as with regular BSS+.
- Clients who are also enrolled in the BSS+ SSO must be exited from the SSO on the same date as used for the BSS+ ESG-CARES [CV] exit.
- Clients must be exited from BSS+ ESG-CARES [CV] by the end of contract **(9/30/2022)**. If that requirement changes, BSS+ Admin staff will notify you. If clients need additional support upon exit and they are eligible, consider enrolling them in regular BSS+ or another available program. ***If clients were enrolled in BSS+ before enrolling in BSS+ ESG-CV, at the conclusion of the ESG-CV grant, they can re-enroll into BSS+, if they are still eligible. They do not have to wait the customary 1 year before re-enrolling into BSS+.***
- If the client is subsequently enrolled in regular BSS+ after exit from BSS+ ESG-CARES [CV] (and the BSS+ SSO) use of SSO funds WILL NOT count towards the 24-month BSS+ enrollment limit or the regular BSS+ financial cap.

TROUBLESHOOTING NEEDS

If partner staff have problems with:

- BSS+ ESG-CARES [CV] and BSS+ SSO program issues, please contact: Linda Horbal at lhoral@caritasofaustin.org or Darnise Jones at djones@caritasofaustin.org
- Check requests for BSS+ ESG-CARES [CV] and BSS+ SSO, should be sent to the BSS+ ESG-CV Mailbox at bssesg-cv@caritasofaustin.org

- Housing referrals and requests to work with the ESG Community Housing Specialists are sent to the BSS+ ESG Referral Mailbox at esgreferrals@caritasofaustin.org or fax your information to 512-735-2007
- HMIS questions or assignment of the BSS+ ESG-CV EDA or BSS+ SSO EDA, contact the ECHO IT HELP DESK at www.austinecho.org
- Basic HMIS data entry or data quality issues, contact Greg Tausch at gtausch@caritasofaustin.org

Please notify the BSS+ Admin staff immediately if you determine a BSS+ ESG-CARES [CV] policy and/or procedure needs further clarification and/or reinterpretation.

OUTLINE FOR PROCESSING BSS+ ESG-CV CHECK REQUESTS

Reminder for Program Transfer Clients: Before any direct client assistance can be spent, client's program transfer form needs to be submitted to BSS+/ESG Program Manager [Linda Horbal at lhorbal@caritasofaustin.org]. She will confirm with ECHO that the client can be transferred into the BSS+ ESG-CV Program. As soon as Linda receives that transfer confirmation, she will notify case manager to proceed with enrollment and submitting check requests for client's expenses.

Outline of documents for first rental assistance check request for all ESG-CV clients:

- Use special "yellow" ESG check request form with unique number
- Before first rental assistance check request can be submitted both the Landlord Rental Assistance Agreement has to be signed by client and property, and Habitability Inspection completed/passed.
- All expenses represented on check request form need to be posted in HMIS Service Transactions before check request is submitted. Service transaction entries are confirmed during check request vetting and before expense is sent to Finance for processing check.
- Documents needed as back-up for check request:
 - ✓ Landlord Rental Assistance Agreement completed & signed by client and property staff
 - ✓ Landlord Incentive Agreement Addendum, if an incentive is being used
 - ✓ LLV signed by property staff (When securing housing for the first time, BSS+ needs an actual property staff member's signature on LLV);
 - ✓ At all times, landlord/property management staff signature at bottom of the LLV is ideal;
 - ✓ If rental or utility debt is included on the LLV and check request, a ledger is required. Please review section on "Client Ledgers" information next. **Remember, ESG-CV does not pay late fees.**
 - ✓ Rental amount on LLV should match the lease and, if it is less or more than what the client normally pays, please explain on the "Additional Information" line of the check request form. In some cases, the client will be paying the balance.
 - ✓ Updated W-9, if the W-9 Vendor Log on BSS+ Website shows it is expired. If not expired, no need to include.
 - ✓ **Lease:** first page with head of household's name(s) and rental amount, plus summary page with all rental details and client's and property staff member's signatures (If case manager is securing housing for the first time and there is no lease, yet, please write that information on the "Additional Information" line on the check request; all other documents are required.)

- ✓ If case manager is working with a *program transfer client*, please attach a copy of the unit's habitability inspection, which at the least is the ESG-CV Minimal Habitability Inspection form provided on BSS+ Website

Outline of documents for recurring rental assistance:

- Use special “yellow” ESG check request form with unique number
- All expenses represented on check request form need to be posted in HMIS Service Transactions before check request is submitted. Service transaction entries are confirmed during check request vetting and before expense is sent to Finance for processing check.
- Documents needed as back-up:
 - ✓ Monthly LLVs: It is ideal for the landlord/property management staff to sign the bottom of LLV.
 - ✓ After housing has been established, a case manager can secure information from the landlord/property management staff via email confirming the monthly fees on LLV; **although, the property's email also must confirm that their email serves as their signature on the LLV.**
 - ✓ Updated W-9, if the W-9 Vendor Log on BSS+ Website shows it is expired. If not expired, no need to include.
 - ✓ **Lease:** first page with head of household's name and rental amount, plus summary page with all details and client's and property staff member's signatures

Reminder: Any rental debt owed to a former property is handled on a separate check request and is governed by different ESG-CV procedures. Normally, ESG-CV does not pay rental late fees, unless they are included in rental debt, which frequently is a one-time payment.